



TS1

SMARTBOB REMOTE UNIT



INSTALLATION and OPERATING INSTRUCTIONS
PLEASE READ CAREFULLY



TABLE OF CONTENTS

SPECIFICATIONS	3
1.0 INTRODUCTION	4
2.0 INSTALLATION	4
2.1 LOCATION AND MOUNTING	4
2.2 POWER WIRING	5
2.3 RS-485 NETWORK WIRING	5
2.4 RS-485 NETWORK BIASING AND TERMINATION	6
2.5 WIRELESS MODEM	7
2.6 SETTING THE ADDRESS SWITCH	8
2.7 EXTERNAL OVERRIDE	10
2.8 PROTO JUMPER SETTING	10
3.0 TESTING THE REMOTE OPERATION	11
3.1 TS1 MANUAL CYCLE AND RETRACT SWITCHES	11
3.2 LED INDICATORS	11
3.3 TROUBLESHOOTING	12
4.0 WARRANTY AND CUSTOMER SERVICE	12
4.1 LIMITED WARRANTY	12
4.2 CUSTOMER SERVICE	12
CABLE REPLACEMENT INSTRUCTIONS	13
LIMITING THE NYLON CABLE LENGTH	14
BOB ASSEMBLY INSTRUCTIONS	15
SMARTBOB REMOTE MOUNTING TEMPLATE	16



SMARTBOB TS1 SPECIFICATIONS

Power Requirements: ----- 115 VAC 60 Hz
(230 VAC Models are available)

Power Consumption: ----- 21 VA Continuous 37 VA Intermittent

Current Draw (RMS): ----- @115VAC: 0.18 A Continuous 0.32 A Intermittent
@230VAC: 0.09 A Continuous 0.16 A Intermittent

Temperature: ----- 32° F to +140° F (0° C to +60° C) without heater
-20° F to +140° F (-28° C to +60° C) with optional heater

Measurement Range: ----- -30 Feet Maximum

Accuracy: ----- 2% or 7 inches

Resolution: ----- 0.1 ft (0.03m)

Communication: ----- RS 485 Half Duplex

Wiring Distance: ----- 4000 ft (1220m)
(wireless option available)

Enclosure: ----- Type 4X, 5, 12

Conduit Entry: ----- Two 3/4 inch KO's

Weight: ----- 10 lbs.

Width: ----- 11 inches

Height: ----- 13 inches

Depth: ----- 9 inches

Cable: ----- -Braided Nylon 90 LB Tensile Strength



1.0 INTRODUCTION

The BinMaster SmartBob TS1 is a remote on demand level measurement sensing unit. It is designed to communicate with a personal computer running BinMaster e-Bob or IMS software, or a Bin Master SBC, SBC-A, or RSU control unit. Communication can be either over a hard wired RS-485 network or wireless using an optional built-in wireless modem. A single TS1 with a wireless modem can be hardwired to a cluster of other TS1 units to activate simple and economical installation configurations.

In operation, the TS1 lowers a weighted bob to the surface of material, measuring the distance and reporting the result. A micro controller counts pulses from an optical encoder to determine this distance. Slack in the cable when the bob touches the material causes the unit to reverse and retract the bob. The retract distance is also measured for diagnostic purposes.

Figures 4a through 4c illustrate a few possible system configurations for both hard wired and wireless installations. Many other configurations to fit specific needs are possible.

2.0 INSTALLATION

2.1 LOCATION AND MOUNTING

The TS1 remote unit comes with one of several mounting options. The appropriate mounting option should be specified at the time of ordering. When mounting the TS1 to the top of the vessel, it is important that the unit is perpendicular so that in operation the cable does not rub on anything. The location of the TS1 on the vessel roof should be such that it will give a somewhat average level of the material. For the case of a round vessel, center filled with dry material, the mounting position which will give a mathematical average of the material level is $1/3$ of the vessel radius from the outer edge. This is true mathematically for any angle of repose.

FIGURE 1

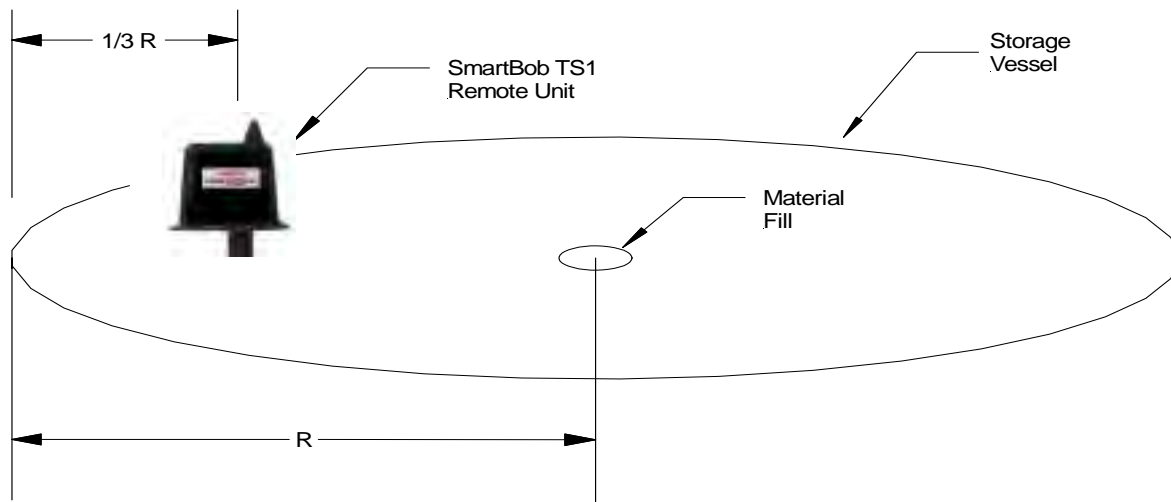

2.2 POWER WIRING

All wiring should be installed according to local and/or national codes. Refer to Figure 2 for the connection of the power wiring. The AC input power connects to the 2 pole terminal block. The neutral wire should be connected to the terminal on the right and the "LINE" conductor connected to the terminal on the left. The terminal on the left wires through the fuse to the transformer.

A green ground screw is provided in the SmartBob TS1 for electrically grounding the unit. A good Electrical ground must be connected to the TS1 for safety and to bleed off any static electrical charges that might built up in the TS1. It is recommended that both the power and the RS-485 communication cable be ran in metal conduit.

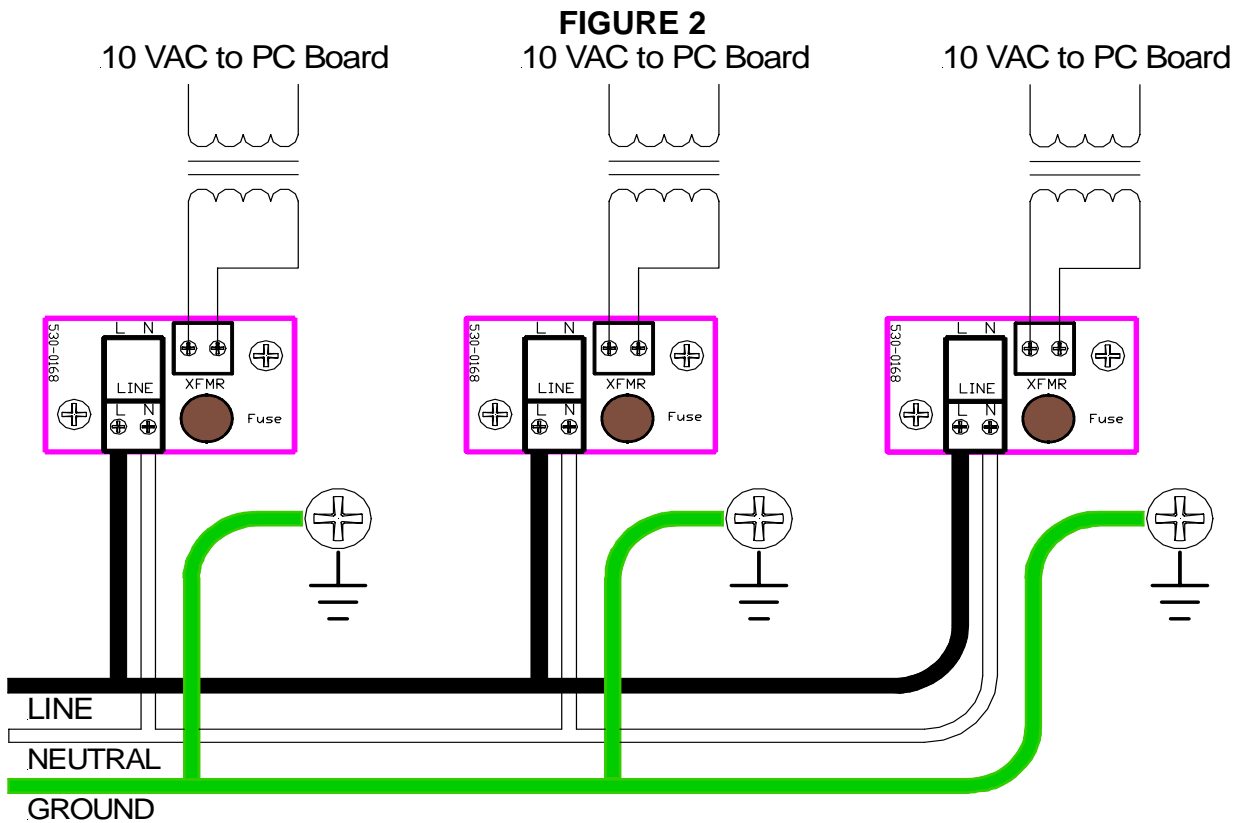

2.3 RS-485 NETWORK WIRING

RS-485 network cable consists of a twisted pair of wires with an outer shield such as Belden 9463 or similar. The cable is run from TS1 to TS1 with each unit connected in a daisy chain fashion with no branch or stub runs. Polarity of the twisted pair must be maintained throughout the entire network. The terminals for the RS-485 connection on the TS1 circuit board are labeled with polarity marks to help prevent cross wiring. A terminal connection is also provided for the outer shield of the cable.

NOTE: Where moisture may be a problem, use conduit sealing compound to prevent moisture from entering the TS1 through electrical conduits.

FIGURE 3

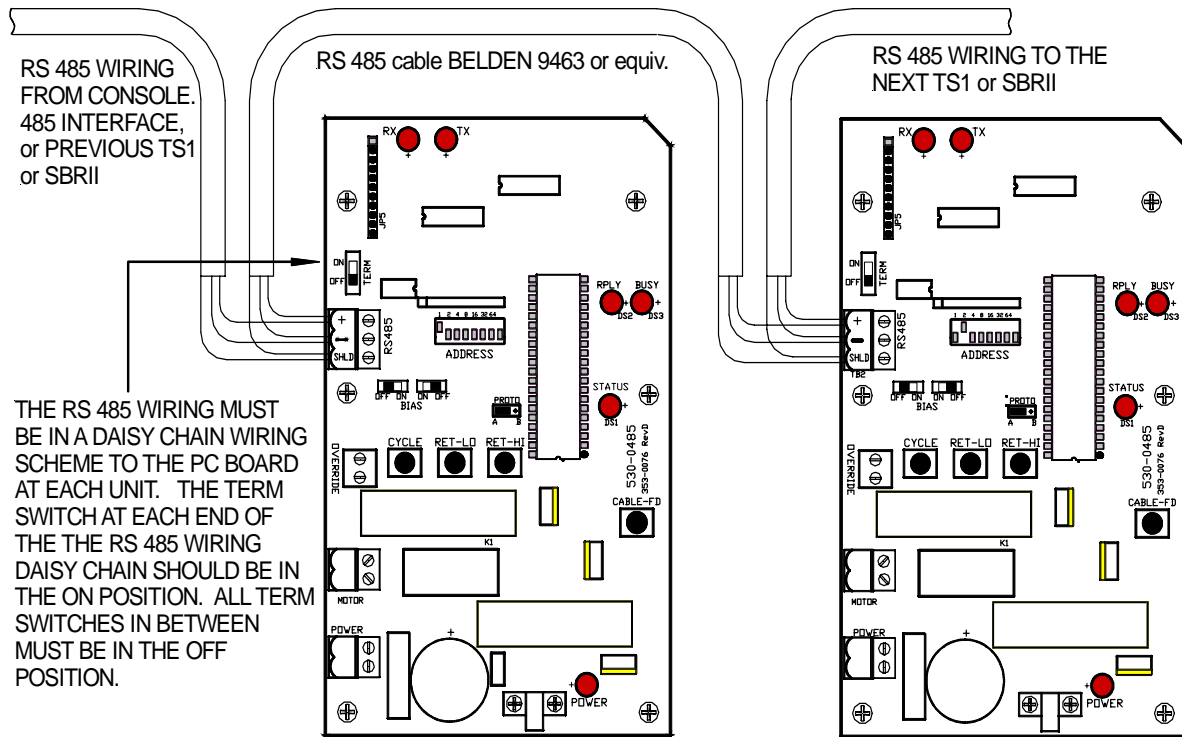

2.4 RS-485 NETWORK BIASING AND TERMINATION

A proper installation of an RS-485 network will only have a resistive termination at each end of the cable run. Therefore, a cable from the computer interface will be terminated at the interface unit and at the last TS1 on the network. The BinMaster RS 232 to 485 interface unit will have its internal NTR jumper ON and the last TS1 on the network will have its TERM switch ON. All others should be OFF. The RS-232 to 485 interface provides network bias and all TS1 units hardwired to it should have their BIAS jumpers OFF.

For a TS1 with a wireless modem which is driving a network of other TS1 or SmartBob SBRXII units, the TS1 with the wireless modem should have its BIAS jumpers ON and its TERM switch ON. All other TS1 units must have their BIAS jumpers OFF and except for the very last unit on the network must have their TERM switches (in TS1) or NTR switches (in SBRXII) OFF. The very last unit will have its TERM switch (NTR in SBRXII) ON and its BIAS jumpers OFF.

Note: The **TERM** switch in the TS1 units performs the same function as the **NTR** switch in the RS 232 to 485 interfaces, RSU or SBC consoles, or SBRXII Remote units.

FIGURE 4a -- WIRED RS 485 FROM COMPUTER TO TS1 UNITS

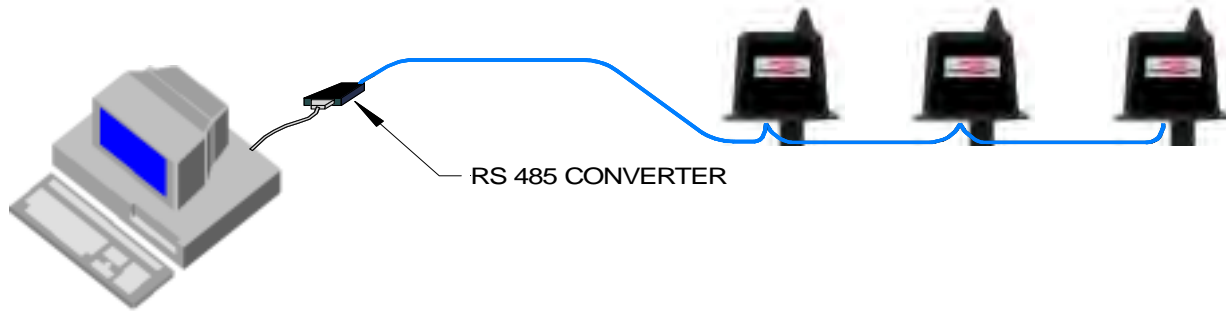
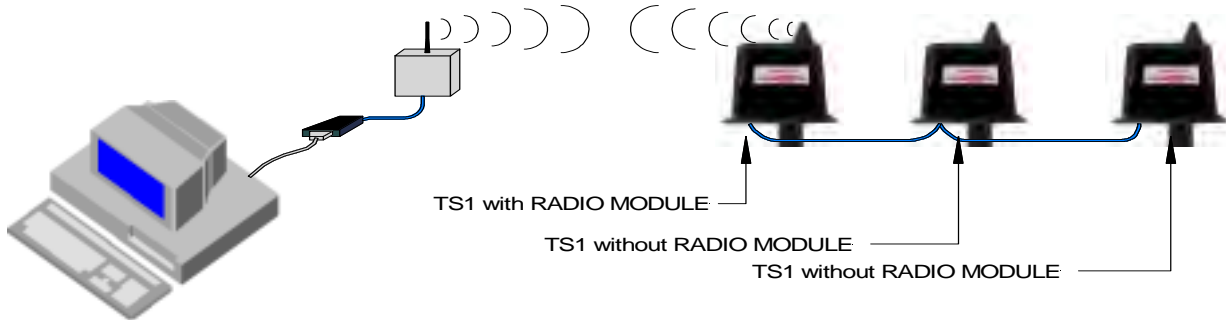
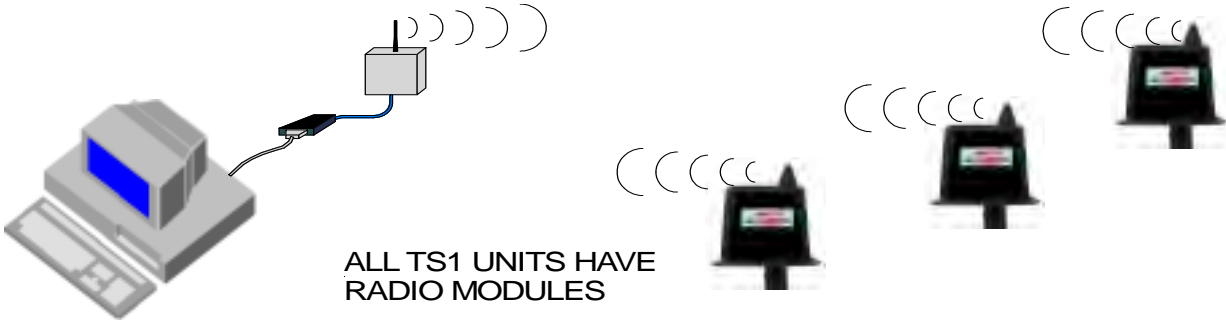

FIGURE 4b -- WIRELESS FROM COMPUTER TO ONE TS1 WITH A RADIO MODULE, WIRED RS 485 TO OTHER TS1's WITHOUT RADIO MODULES



NOTE: There can be only **one** TS1 unit having a wireless modem connected to each wired RS-485 network. Do not connect multiple TS1 units with wireless modems to the same RS-485 network.

FIGURE 4c -- WIRELESS FROM COMPUTER TO ALL TS1's WITH RADIO MODULES



2.5 WIRELESS MODEM

The optional wireless modem allows units to communicate without having interconnecting wires. A system may consist of all TS1 units having wireless modems or just one TS1 unit with a wireless modem and other TS1 units without wireless modems hard wired to it with RS-485 cable. In such a case where one TS1 with a wireless modem drives a hardwired RS-485 network, the TS1 with the wireless modem must have both of its BIAS jumpers placed in the ON position and its TERM switch in the ON position. All other units on the network should have their BIAS jumpers in the OFF position. The last unit on the RS-485 network should have its TERM switch ON and all other units, except the one with the wireless modem, should have their TERM switch OFF.

2.6 SETTING THE ADDRESS SWITCH

Each TS1 has an ADDRESS switch located on its circuit board. An address which corresponds to that in the computer controlling software or other controlling device must be set on this switch. The address set by this switch is in binary and the value of each switch lever is printed on the TS1 circuit board above the switch. The Binary value of each lever in the up ON position are added together to give the address number. Consult the following chart to assist in determining the switch settings for any desired address number.

Note: The RSU control unit only operates using address 1. It is intended to function with a single TS1 unit on an independent RS-485 cable. The address of that TS1 must be set to 1.



BIN ADDRESS DIP SWITCHES

BIN ADDRESS	DIP SWITCH SETTING								BIN ADDRESS	DIP SWITCH SETTING							
	1	2	3	4	5	6	7	8		1	2	3	4	5	6	7	8
1	ON	OFF	OFF	OFF	OFF	OFF	OFF	OFF	66	OFF	ON	OFF	OFF	OFF	OFF	ON	OFF
2	OFF	ON	OFF	OFF	OFF	OFF	OFF	OFF	67	ON	ON	OFF	OFF	OFF	OFF	ON	OFF
3	ON	ON	OFF	OFF	OFF	OFF	OFF	OFF	68	OFF	OFF	ON	OFF	OFF	OFF	ON	OFF
4	OFF	OFF	ON	OFF	OFF	OFF	OFF	OFF	69	ON	OFF	ON	OFF	OFF	OFF	ON	OFF
5	ON	OFF	ON	OFF	OFF	OFF	OFF	OFF	70	OFF	ON	ON	OFF	OFF	OFF	ON	OFF
6	OFF	ON	ON	OFF	OFF	OFF	OFF	OFF	71	ON	ON	ON	OFF	OFF	OFF	ON	OFF
7	ON	ON	ON	OFF	OFF	OFF	OFF	OFF	72	OFF	OFF	OFF	ON	OFF	OFF	ON	OFF
8	OFF	OFF	OFF	ON	OFF	OFF	OFF	OFF	73	ON	OFF	OFF	ON	OFF	OFF	ON	OFF
9	ON	OFF	OFF	ON	OFF	OFF	OFF	OFF	74	OFF	ON	OFF	ON	OFF	OFF	ON	OFF
10	OFF	ON	OFF	ON	OFF	OFF	OFF	OFF	75	ON	ON	OFF	ON	OFF	OFF	ON	OFF
11	ON	ON	OFF	ON	OFF	OFF	OFF	OFF	76	OFF	OFF	ON	ON	OFF	OFF	ON	OFF
12	OFF	OFF	ON	ON	OFF	OFF	OFF	OFF	77	ON	OFF	ON	ON	OFF	OFF	ON	OFF
13	ON	OFF	ON	ON	OFF	OFF	OFF	OFF	78	OFF	ON	ON	ON	OFF	OFF	ON	OFF
14	OFF	ON	ON	ON	OFF	OFF	OFF	OFF	79	ON	ON	ON	ON	OFF	OFF	ON	OFF
15	ON	ON	ON	ON	OFF	OFF	OFF	OFF	80	OFF	OFF	OFF	OFF	ON	OFF	ON	OFF
16	OFF	OFF	OFF	OFF	ON	OFF	OFF	OFF	81	ON	OFF	OFF	OFF	ON	OFF	ON	OFF
17	ON	OFF	OFF	OFF	ON	OFF	OFF	OFF	82	OFF	ON	OFF	OFF	ON	OFF	ON	OFF
18	OFF	ON	OFF	OFF	ON	OFF	OFF	OFF	83	ON	ON	OFF	OFF	ON	OFF	ON	OFF
19	ON	ON	OFF	OFF	ON	OFF	OFF	OFF	84	OFF	OFF	ON	OFF	ON	OFF	ON	OFF
20	OFF	OFF	ON	OFF	ON	OFF	OFF	OFF	85	ON	OFF	ON	OFF	ON	OFF	ON	OFF
21	ON	OFF	ON	OFF	ON	OFF	OFF	OFF	86	OFF	ON	ON	OFF	ON	OFF	ON	OFF
22	OFF	ON	ON	OFF	ON	OFF	OFF	OFF	87	ON	ON	ON	OFF	ON	OFF	ON	OFF
23	ON	ON	ON	OFF	ON	OFF	OFF	OFF	88	OFF	OFF	OFF	ON	ON	OFF	ON	OFF
24	OFF	OFF	OFF	ON	ON	OFF	OFF	OFF	89	ON	OFF	OFF	ON	ON	OFF	ON	OFF
25	ON	OFF	OFF	ON	ON	OFF	OFF	OFF	90	OFF	ON	OFF	ON	ON	OFF	ON	OFF
26	OFF	ON	OFF	ON	ON	OFF	OFF	OFF	91	ON	ON	OFF	ON	ON	OFF	ON	OFF
27	ON	ON	OFF	ON	ON	OFF	OFF	OFF	92	OFF	OFF	ON	ON	ON	OFF	ON	OFF
28	OFF	OFF	ON	ON	ON	OFF	OFF	OFF	93	ON	OFF	ON	ON	ON	OFF	ON	OFF
29	ON	OFF	ON	ON	ON	OFF	OFF	OFF	94	OFF	ON	ON	ON	ON	OFF	ON	OFF
30	OFF	ON	ON	ON	ON	OFF	OFF	OFF	95	ON	ON	ON	ON	ON	OFF	ON	OFF
31	ON	ON	ON	ON	ON	OFF	OFF	OFF	96	OFF	OFF	OFF	OFF	ON	OFF	ON	OFF
32	OFF	OFF	OFF	OFF	OFF	ON	OFF	OFF	97	ON	OFF	OFF	OFF	OFF	ON	ON	OFF
33	ON	OFF	OFF	OFF	OFF	ON	OFF	OFF	98	OFF	ON	OFF	OFF	OFF	ON	ON	OFF
34	OFF	ON	OFF	OFF	OFF	ON	OFF	OFF	99	ON	ON	OFF	OFF	OFF	ON	ON	OFF
35	ON	ON	OFF	OFF	OFF	ON	OFF	OFF	100	OFF	OFF	ON	OFF	OFF	ON	ON	OFF
36	OFF	OFF	ON	OFF	OFF	ON	OFF	OFF	101	ON	OFF	ON	OFF	OFF	ON	ON	OFF
37	ON	OFF	ON	OFF	OFF	ON	OFF	OFF	102	OFF	ON	ON	OFF	OFF	ON	ON	OFF
38	OFF	ON	ON	OFF	OFF	ON	OFF	OFF	103	ON	ON	ON	OFF	OFF	ON	ON	OFF
39	ON	ON	ON	OFF	OFF	ON	OFF	OFF	104	OFF	OFF	OFF	ON	OFF	ON	ON	OFF
40	OFF	OFF	OFF	ON	OFF	ON	OFF	OFF	105	ON	OFF	OFF	ON	OFF	ON	ON	OFF
41	ON	OFF	OFF	ON	OFF	ON	OFF	OFF	106	OFF	ON	OFF	ON	OFF	ON	ON	OFF
42	OFF	ON	OFF	ON	OFF	ON	OFF	OFF	107	ON	ON	OFF	ON	OFF	ON	ON	OFF
43	ON	ON	OFF	ON	OFF	ON	OFF	OFF	108	OFF	OFF	ON	ON	OFF	ON	ON	OFF
44	OFF	OFF	ON	ON	OFF	ON	OFF	OFF	109	ON	OFF	ON	ON	OFF	ON	ON	OFF
45	ON	OFF	ON	ON	OFF	ON	OFF	OFF	110	OFF	ON	ON	ON	OFF	ON	ON	OFF
46	OFF	ON	ON	ON	OFF	ON	OFF	OFF	111	ON	ON	ON	ON	OFF	ON	ON	OFF
47	ON	ON	ON	ON	OFF	ON	OFF	OFF	112	OFF	OFF	OFF	OFF	ON	ON	ON	OFF
48	OFF	OFF	OFF	OFF	ON	ON	OFF	OFF	113	ON	OFF	OFF	OFF	ON	ON	ON	OFF
49	ON	OFF	OFF	OFF	ON	ON	OFF	OFF	114	OFF	ON	OFF	OFF	ON	ON	ON	OFF
50	OFF	ON	OFF	OFF	ON	ON	OFF	OFF	115	ON	ON	OFF	OFF	ON	ON	ON	OFF
51	ON	ON	OFF	OFF	ON	ON	OFF	OFF	116	OFF	OFF	ON	OFF	ON	ON	ON	OFF
52	OFF	OFF	ON	OFF	ON	ON	OFF	OFF	117	ON	OFF	ON	OFF	ON	ON	ON	OFF
53	ON	OFF	ON	OFF	ON	ON	OFF	OFF	118	OFF	ON	ON	OFF	ON	ON	ON	OFF
54	OFF	ON	ON	OFF	ON	ON	OFF	OFF	119	ON	ON	ON	OFF	ON	ON	ON	OFF
55	ON	ON	ON	OFF	ON	ON	OFF	OFF	120	OFF	OFF	OFF	ON	ON	ON	ON	OFF
56	OFF	OFF	OFF	ON	ON	ON	OFF	OFF	121	ON	OFF	OFF	ON	ON	ON	ON	OFF
57	ON	OFF	OFF	ON	ON	ON	OFF	OFF	122	OFF	ON	OFF	ON	ON	ON	ON	OFF
58	OFF	ON	OFF	ON	ON	ON	OFF	OFF	123	ON	ON	OFF	ON	ON	ON	ON	OFF
59	ON	ON	OFF	ON	ON	ON	OFF	OFF	124	OFF	OFF	ON	ON	ON	ON	ON	OFF
60	OFF	OFF	ON	ON	ON	ON	OFF	OFF	125	ON	OFF	ON	ON	ON	ON	ON	OFF
61	ON	OFF	ON	ON	ON	ON	OFF	OFF	126	OFF	ON	ON	ON	ON	ON	ON	OFF
62	OFF	ON	ON	ON	ON	ON	OFF	OFF	127	ON	ON	ON	ON	ON	ON	ON	OFF
63	ON	ON	ON	ON	ON	ON	OFF	OFF	128	OFF	OFF	OFF	OFF	OFF	OFF	OFF	ON
64	OFF	OFF	OFF	OFF	OFF	OFF	ON	OFF	129	ON	OFF	OFF	OFF	OFF	OFF	OFF	ON
65	ON	OFF	OFF	OFF	OFF	OFF	ON	OFF	130	OFF	ON	OFF	OFF	OFF	OFF	OFF	ON



2.7 EXTERNAL OVERRIDE

This feature can be used to prohibit measurements during a vessel filling cycle. The IMS software will notify the user that a measurement cannot be taken while a filling operation is in progress. Located on the SmartBob circuit board (just below the RS-485 terminals), is the terminal block labeled **VERRIDE**. A connection must exist across these terminals for normal operation of the remote unit, see Figure 6. A contact on an external relay can be used to disable the remote unit during a fill cycle to prevent burying the Bob. The use of this feature is optional, if not used, leave the factory installed jumper in the terminal block.

FIGURE 6

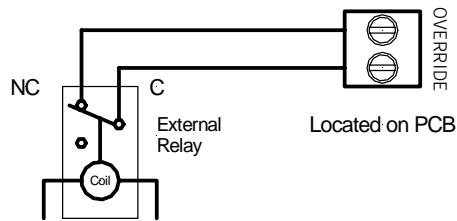

2.8 PROTO JUMPER SETTING

The TS1 is capable of operating in two different modes as selected by the PROTO jumper located on the TS1 circuit board. The desired mode is dependent upon what type of controlling device the TS1 is operating with and is normally set at the factory in accordance with a particular customer order. PROTO A operates in a polling mode and PROTO B in a non-polling mode. The PROTO setting and corresponding controlling devices are listed below.

PROTO A

- e-Bob software
- SBC-A console
- QUCM
- MUCM

PROTO B

- IMS software
- SBC console
- RSU console

3.0 TESTING THE REMOTE OPERATION

3.1 TS1 MANUAL CYCLE AND RETRACT SWITCHES

The TS1 circuit board contains several push switches which allow certain manual operations of the unit. The function of each push button switch is described below.

- CYCLE** Momentarily pushing this button starts a measurement cycle. The bob will descend and retract as in normal operation.
- RET HI** When this switch is pushed, the motor retracts the bob under HI torque. This switch may be used to help free a buried bob. Do not push this switch when the bob is seated at the top or the cable may pull down in its supply spool and become stuck.
- RET LO** Use this switch to retract a free bob. As long as the switch is pushed the motor runs under low torque and allows the bob to be retracted and seated at the top without stressing the cable.
- FWD** This switch allows the motor to run forward and let out line to lower a bob. It only runs while the switch is held in.

3.2 LED INDICATORS

- BUSY** This LED indicates when data traffic is present on the RS-485 network.
- RPLY** This LED indicates when that particular TS1 sends data out on the RS-485 network.
- RX** If a wireless modem is installed, this LED indicates when data is received over the wireless. Lighting of this LED should be immediately followed by the lighting of the BUSY LED.
- TX** This LED indicates when data is transmitted over the air from the wireless modem. This LED should light when ever any unit on the RS-485 network sends data.
- STATUS** This LED turns on when the unit switches to low torque retract mode. This LED should light at the end of each retract cycle and on power up of the TS1.

NOTE: On power up, the TS1 performs a low torque retract operation to insure that the bob is fully retracted following a power off period.



3.3 TROUBLESHOOTING

If the remote fails to cycle, verify that the Input Power is present at the terminal block and that the POWER LED located on the circuit board (in lower right corner), is lit. This LED should be lit whenever the power is present at the board terminals. If the unit still does not operate, consult the factory at 800 278-4241.

4.0 WARRANTY AND CUSTOMER SERVICE

4.1 LIMITED WARRANTY

The manufacturer warrants this equipment for one (1) year according to the following terms:

- 1.) This warranty extends to the original purchaser only and commences on the date of original purchase. The original purchaser must mail to the manufacturer the "Warranty Registration" card to confirm the equipment purchase. Failure to do so may void the warranty.
- 2.) The manufacturer will repair or replace any part of this equipment found to be defective, provided such part is delivered prepaid to the factory. Manufacturer's obligation is limited to the cost of material and labor to repair or replace and does not include transportation expenses.
- 3.) This warranty shall not apply to any product that has, in our judgement, been tampered with, altered, subject to misuse, neglect or accident. In addition, the warranty does not extend to repairs made necessary by normal wear.
- 4.) This warranty is in lieu of all other warranties, expressed or implied.

4.2 CUSTOMER SERVICE

BinMaster offers a toll-free Customer Service phone number, **800 278-4241**. You may call the Customer Service Department for technical and application assistance Monday through Friday from 8:00 AM to 5:00 PM Central Time. International customers call us at **(402) 434-9102** or reach us via **Fax** at **(402) 434-9133**. E-mail questions to "info@binmaster.com".



Cable Replacement Instructions

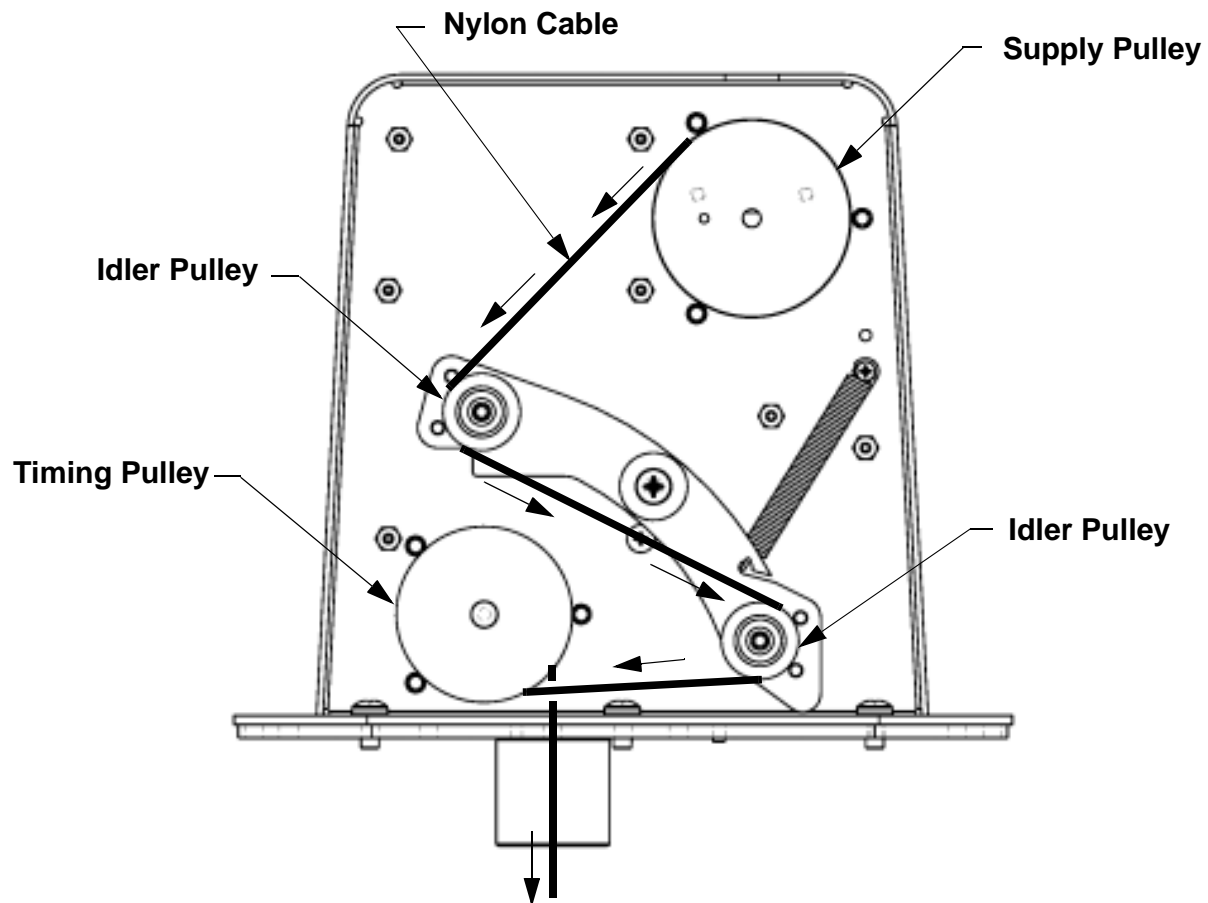

- 1.) Remove the Bob and discard the old nylon cable.
- 2.) Tie a knot 18" from the end of the cable. This will keep from paying out all of the cable in the event the unit is lowered into a empty vessel.
- 3.) Thread the same end of the cable through the hole on the front of the supply pulley flange and tie a knot to secure the cable to the supply pulley.
- 4.) Located on the PC board is a button labeled "RET-LO". Pressing and holding the button will wind the cable onto the supply pulley.
- 5.) Thread the nylon cable through and around the idler pulleys and the timing pulley as shown in the above illustration.

Limiting the Nylon Cable Length

It is important to limit the length of the cable on the TS1 remote, so that the bob is not lowered into an airlock, screw conveyor or any other area that the Bob might become trapped in. The TS1 is shipped with 30' of cable unless otherwise specified. Disregard these instructions if the unit was ordered with the exact amount of cable necessary for your vessel.

- 1.) Remove the cable from the supply pulley by pressing the "CYCLE" button in the center of the PC board. Keeping the cable taut, pull on the cable as the cable spools off the pulley. When the line is all payed out, the motor will reverse and try to rewind the cable. Hold the cable tight so it cannot rewind. The motor should now be shut off.
- 2.) From the throat of the TS1, measure the height of your vessel or the maximum distance you want the bob to travel. Cut the cable at this distance.
- 3.) Attach the cable to the bob as shown in the bob assembly instructions.
- 4.) Test the knot by pulling on the cable and bob.
- 5.) Rewind the cable onto the supply pulley or lower the cable and bob into the vessel. To rewind onto the supply pulley: Pull the cable taut. Load the supply pulley by pressing (and hold) the "RET-LO" button located on the circuit board. Pressing this button will start the supply pulley turning in a clockwise direction, with the cable winding over the top.
- 6.) Continue installation of the unit on your vessel.



Bob Assembly Instructions

(With Nylon Cable)

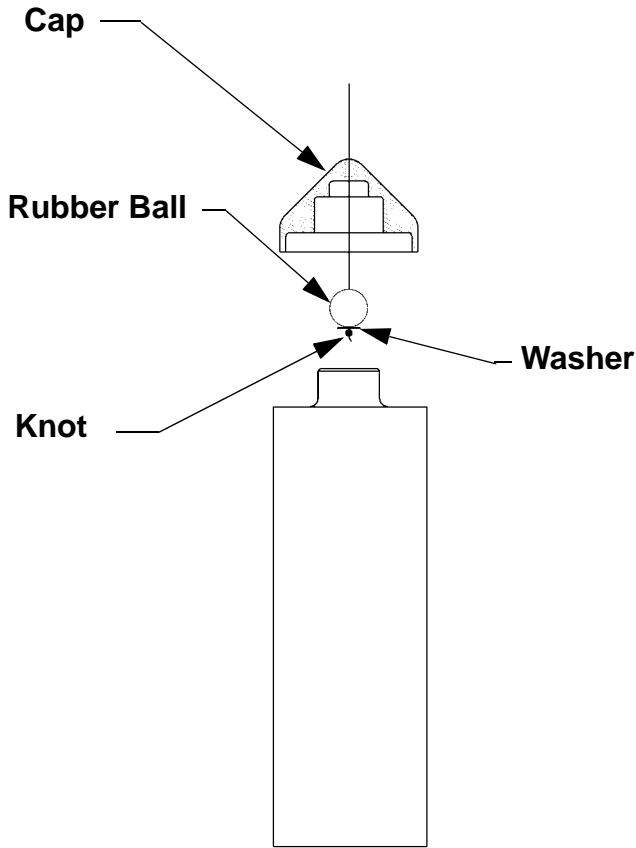

Digestible Bottle

B7

This Bob is designed for granular material with a density from 20 lbs. per cubic foot and greater. The B7 Bob should be filled with a material that is compatible with the material that is stored in the storage bin. Total weight of the Bob when full should be 16 oz. The B7 is made from an engineering plastic which will not damage the material handling auger in the unlikely event that the Bob should become separated from the unit.

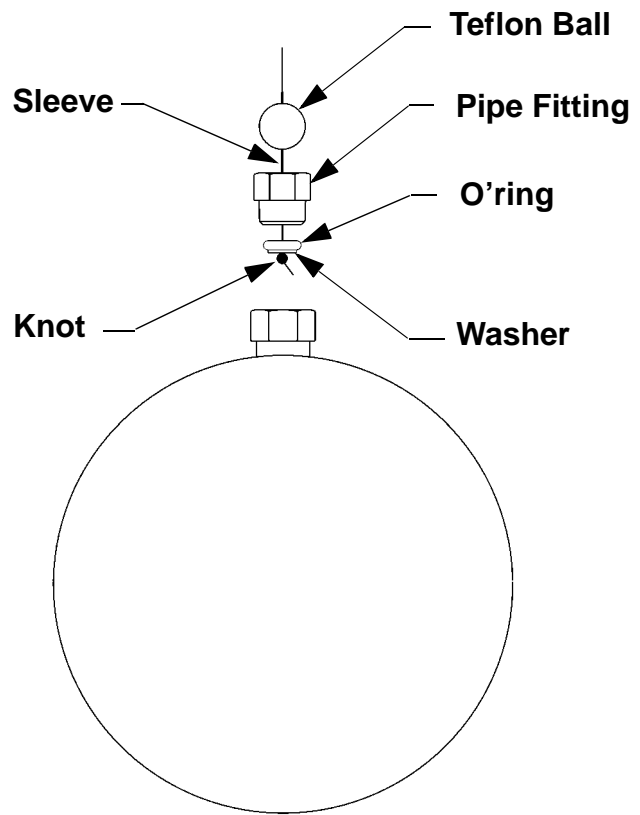

Spherical Float

B8

This Bob is a hollow 5" sphere made of stainless steel and is designed for bulk products with a density from 1.5 lbs. to 20 lbs. per cubic foot. This Bob may also be used in liquid applications.

SmartBob Remote Mounting Template

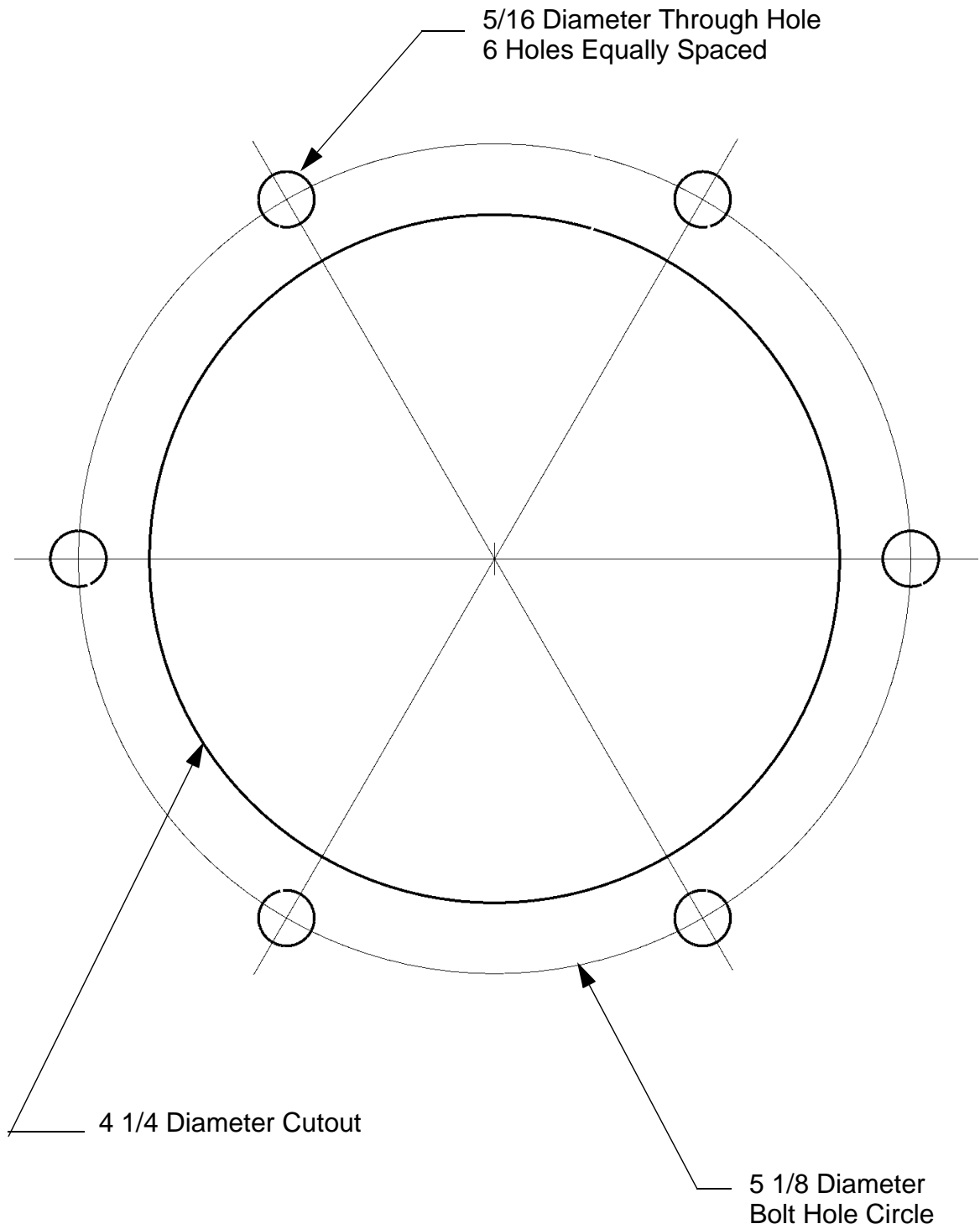

SmartBob Remote Mounting Template

7.00 inch Bolt Circle

